

Safeguarding Applications and Wiring Diagrams

Cat 1 Stop with Guardlocking Interlock and Proximity Sensors

TLSZR-GD2, 872C, GLP, PowerFlex 45

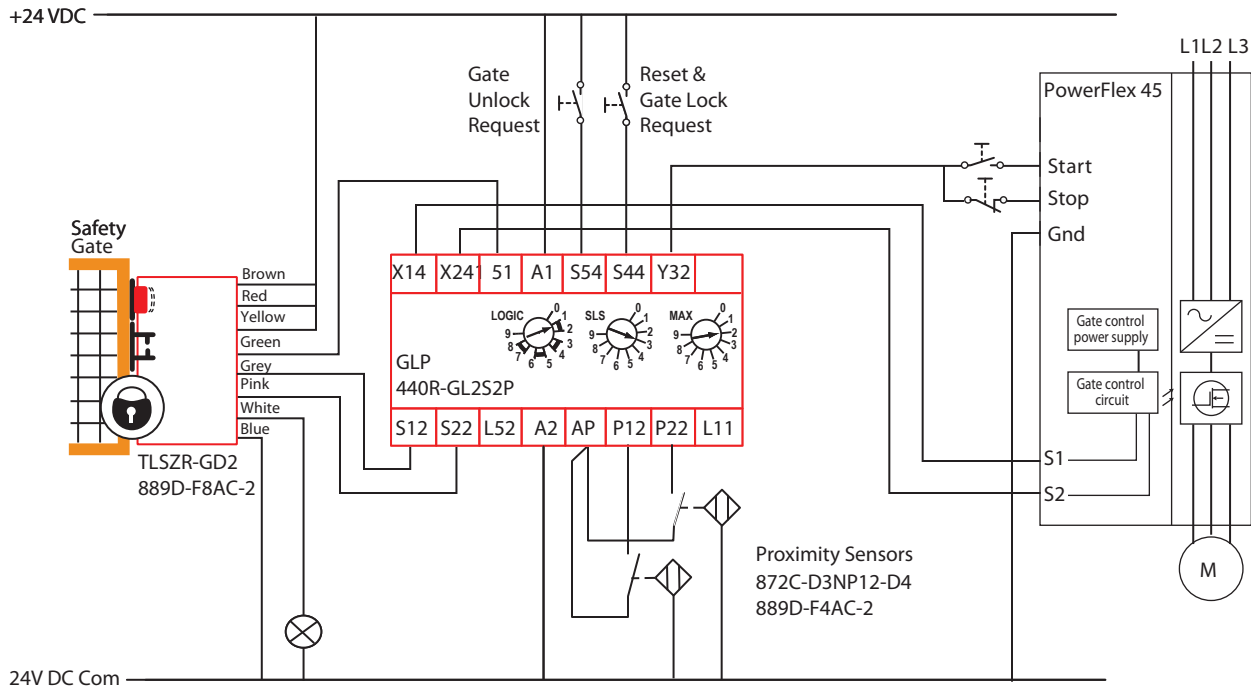

Circuit Status

The gate is closed and locked. The motor is off. The GLP is ready for reset. The GLP has a Logic setting of 1: (Category 1 Stop with Logic IN OFF), a Safe Limited Speed (SLS) setting of 3 (3Hz) and a Maximum speed setting of 2 (20Hz). The safety outputs (X14 & X24), the single wire safety output (L11) and the auxiliary output (Y32) are OFF. NOTE: Start the GLP logic configuration from "0" to configure X14 and X24 for use as safety outputs.

Operating Principle

STARTING: Press the reset button to lock the gate and turn the GLP safety outputs ON. Press the Start button to turn the motor ON.

STOPPING: Normal production stopping is performed by pressing the Stop button. Access through the safety gate is initiated by pressing the Gate Unlock Request button. The Y32 output of the GLP turns OFF and initiates a stop command to the drive. When the speed detected by the proximity sensors drops below the safe limited speed, the gate becomes unlocked and the safety outputs turn OFF. The PowerFlex drive goes to a safe off state. If the motor has not already stopped, the motor coasts to a stop.

OVERSPEED: If the proximity sensors detect a speed greater than the maximum speed (20Hz), the auxiliary output (Y32), the safety outputs (X14 & X24) and the single wire safety output (L11) turn off. The PWR/Fault indicator flashes at a 3X rate. When the speed drops below the max speed limit, press the Reset button to clear the fault.

Fault Detection

Upon power-up, the safety devices perform internal checks. The TLSZR has OSSD outputs and checks for crossfaults. The GLP safety outputs are pulse tested to check for faults. The proximity sensors are continuously tested by requiring that both sensors cannot be OFF at the same time. The PowerFlex 45 performs its own internal safety checks, and requires two safety signals to enable the drive.

Ratings

The safety function meets the safety performance requirements of SIL CL2 per IEC 62061:2005 and has a Category 3 structure that can be used in systems requiring Performance Levels up to PLd per ISO13829-1:2008. This circuit executes a Category 1 stop.

Safeguarding Applications and Wiring Diagrams

Cat 1 Stop with Guardlocking Interlock and Proximity Sensors

TLS3-GD2, 872C, GLP, PowerFlex 70

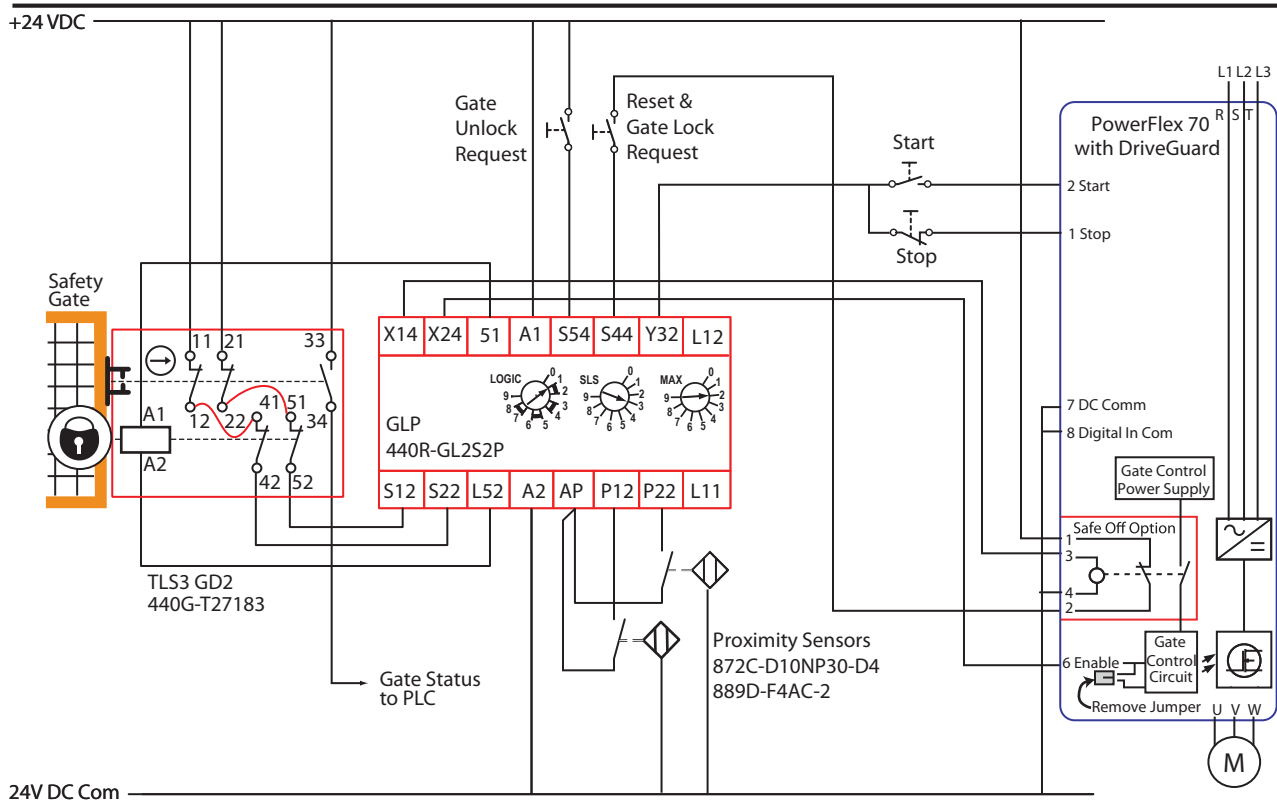

Circuit Status

The gate is closed and locked. The motor is off. The GLP is ready for reset. The GLP has a Logic setting of 1: (Category 1 Stop with Logic IN OFF), a Safe Limited Speed (SLS) setting of 3 (3Hz) and a Maximum speed setting of 2 (20Hz). The safety outputs (X14 & X24), the single wire safety output (L11) and the auxiliary output (Y32) are OFF. NOTE: Start the GLP logic configuration from "0" to configure X14 and X24 for use as safety outputs.

Operating Principle

STARTING: Press the Reset button to lock the gate and turn the GLP safety outputs ON. Press the Start button to turn the motor ON.

STOPPING: Normal production stopping is performed by pressing the Stop button. Access through the safety gate is initiated by pressing the Gate Unlock Request button. The Y32 output of the GLP turns OFF and initiates a stop command to the drive. When the speed detected by the proximity sensors drops below the safe limited speed, the gate becomes unlocked and the safety outputs turn OFF. The PowerFlex drive goes to a safe off state. If the motor has not already stopped, the motor coasts to a stop.

OVERSPEED: If the proximity sensors detect a speed greater than the maximum speed (20Hz), the auxiliary output (Y32), the safety outputs (X14 & X24) and the single wire safety output (L11) turn off. The PWR/Fault indicator flashes at a 3X rate. When the speed drops below the max speed limit, press the Reset button to clear the fault and energize the safety outputs.

Fault Detection

Upon power-up, the safety devices perform internal checks. The TLS3 has dual channel signals but does not check for crossfaults. The GLP safety outputs are pulse tested to check for faults. The proximity sensors are continuously tested by requiring that both sensors cannot be OFF at the same time. The PowerFlex 70 requires two safety signals to enable the drive.

Ratings

The safety function meets the safety performance requirements of SIL CL2 per IEC 62061:2005 and has a Category 3 structure that can be used in systems requiring Performance Levels up to PLd per ISO13829-1:2008. This circuit executes a Category 1 stop.

Safeguarding Applications and Wiring Diagrams

Category 1 Stop with Guardlocking Interlock and Proximity Sensors

TLS3-GD2, 800F, 872C, GLP, DIS, PowerFlex 70

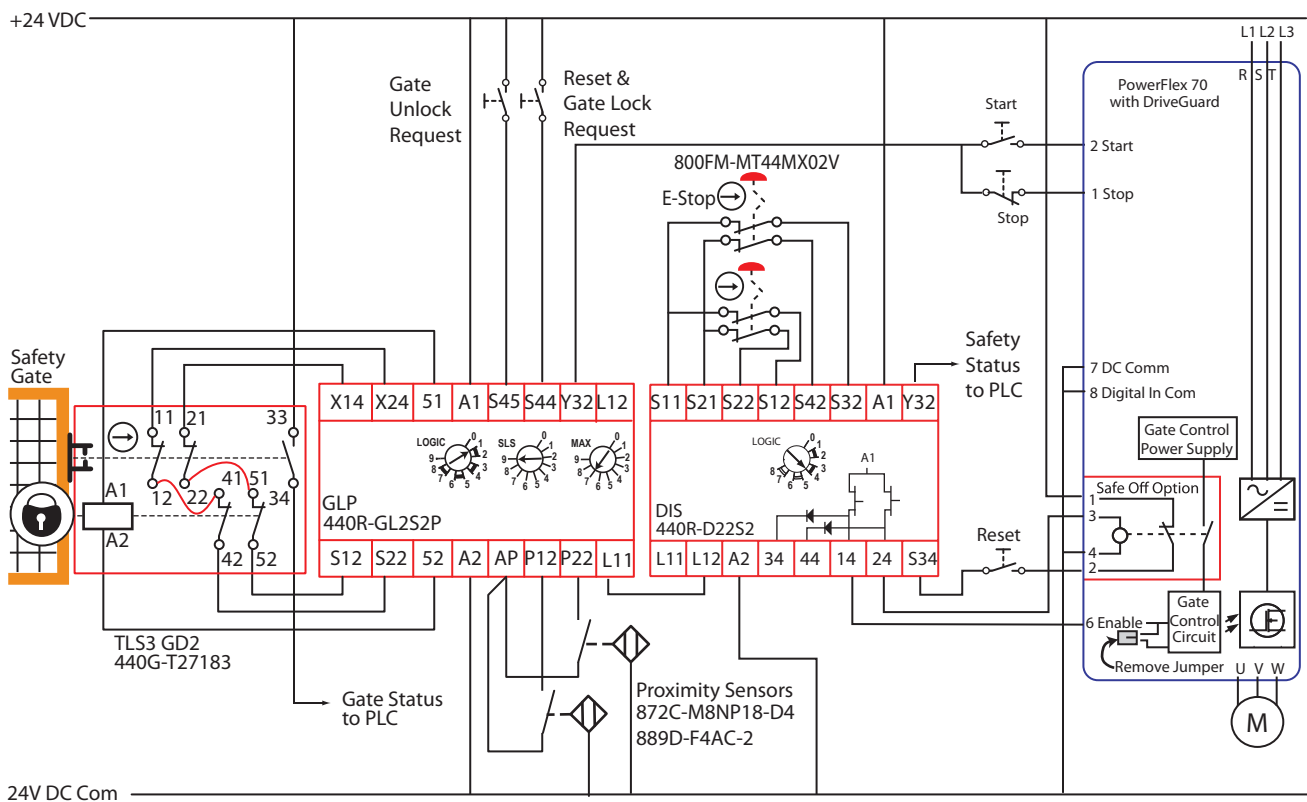

Circuit Status

The gate is closed and locked. The motor is off. The GLP is ready for reset. The GLP has a Logic setting of 1: (Cat 1 Stop with Logic IN OFF), a Safe Limited Speed (SLS) setting of 9 (10 Hz) and a maximum (MAX) speed setting of 7 (1000 Hz). Both E-Stops are closed. The DI is configured to setting 4 [(IN1 AND IN2) AND L12] with monitored manual reset). NOTE: Start the GLP logic configuration from "9" to configure X14 and X24 for use with safety inputs.

Operating Principle

STARTING: Press the Reset button to turn the GLP safety output (L11) ON. This enables the DI relay. Press the Reset button to turn the DI outputs ON and enable the Safe-Off Option of the PowerFlex Drive. Press the Start button to turn the motor ON.

STOPPING: Normal production stopping is performed by pressing the Stop button. Access through the safety gate is initiated by pressing the Unlock Request button. The Y32 output of the GLP turns OFF and initiates a stop command to the drive. When the motor speed drops below the safe limited speed, the GLP unlocks the gate and turns its L11 safety output OFF. Subsequently the DI turns its safety outputs off, and the PowerFlex drive goes to a Safe-Off state. The motor, if not already stopped, coasts to a stop.

The E-stop buttons can be used to initiate a "coast-to-stop". Press the e-stop and the DI outputs turn off, which causes the PowerFlex drive to execute a Safe-Off function. The motor coasts to a stop.

Fault Detection

Upon power-up, the safety devices perform internal checks. The GLP sends out test pulses on X14 & X24 to check for faults on the guardlocking switch. The DI sends out test pulses on S11 & S21 to check for faults on the e-stops. The GLP checks to see that the proximity sensors are connected, by requiring that both sensors cannot be OFF at the same time. The L11/L12 connection is Single Wire Safety connection tested for shorts to power or ground when active. The DIS outputs 14 & 24 are pulse tested to check for shorts to power and ground. The DIS outputs 34 & 44, which are not pulse tested, should be used for compatibility with devices that cannot tolerate the pulse testing.

Ratings

The safety functions meet the safety performance requirements of SIL CL2 per IEC 62061:2005 and has a Category 3 structure that can be used in systems requiring Performance Levels up to PLd per ISO13829-1:2008. This circuit executes a Category 1 stop when requesting gate access through the GLP, and a Category 0 stop when pressing the e-stops.

Safeguarding Applications and Wiring Diagrams

Safe Limited Speed with Guardlocking Interlock and Proximity Sensors

TLSZR-GD2, 871TM, GLP, PowerFlex 70

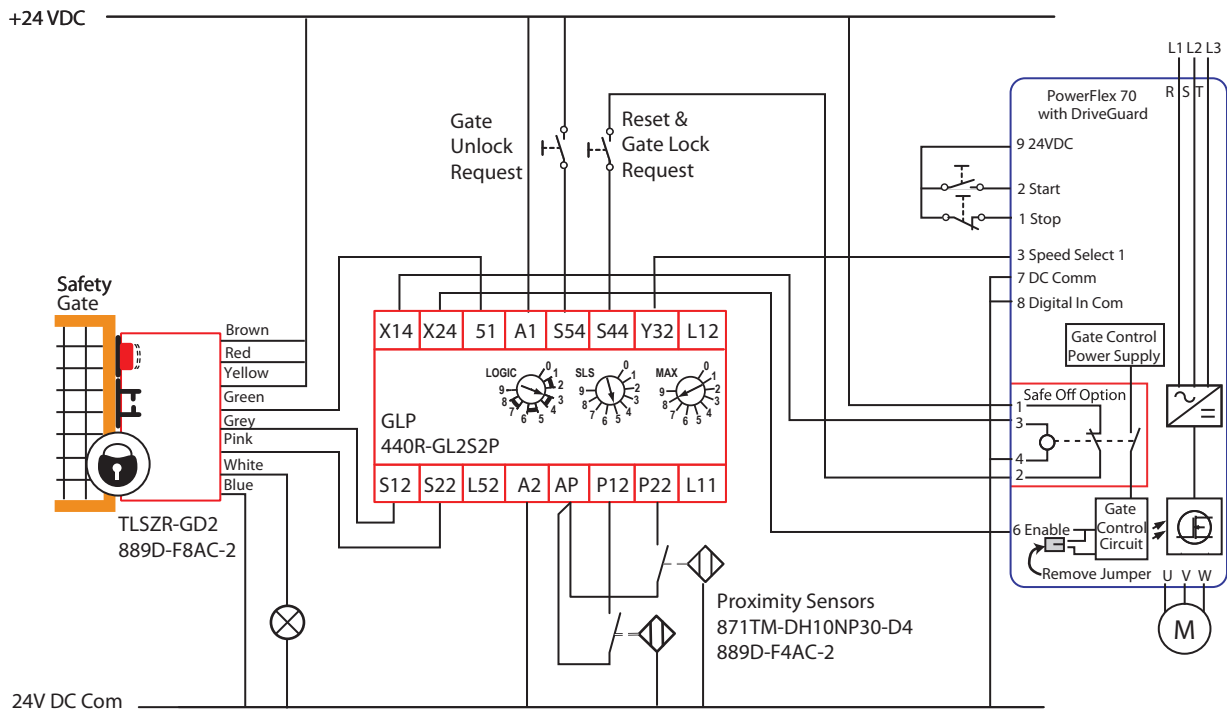

Circuit Status

The gate is closed and locked. The motor is off. The GLP is ready for reset. The GLP has a Logic setting of 3: (Safe Limited Speed with Logic IN OFF), a Safe Limited Speed (SLS) setting of 5 (5Hz) and a Maximum speed setting of 8 (2000Hz). The safety outputs (S11 & S21), the single wire safety output (L11) and the auxiliary output (Y32) are OFF. NOTE: Start the GLP logic configuration from "0" to configure X14 and X24 for use as safety outputs.

Operating Principle

STARTING: Press the Reset button to turn the GLP safety outputs and single wire safety output ON. Press the Start button to turn the motor ON.

STOPPING: Normal production stopping is performed by pressing the Stop button. Access through the safety gate is initiated by pressing the Gate Unlock Request button. The Y32 output of the GLP turns ON and commands the PowerFlex drive to bring the motor to a safe slow speed (less than 5Hz). When the speed detected by the proximity sensors drops below the safe limited speed (5Hz), the gate becomes unlocked. The operator can enter the machine cell, as the motor continues to run at the safe slow speed. After leaving the cell and closing the gate, press the reset button to lock the gate and return the machine to production speeds.

Fault Detection

Upon power-up, the safety devices perform internal checks. The TLSZR has OSSD outputs and checks for crossfaults. The GLP safety outputs are pulse tested to check for faults. The proximity sensors are continuously tested by requiring that both sensors cannot be OFF at the same time. The PowerFlex 70 requires two safety signals to enable the drive. If the gate is unlocked and the motor speed increases beyond the safe limited speed, the GLP turns its safety and single wire safety outputs OFF.

OVERSPEED: If the proximity sensors detect a speed greater than the maximum speed (2000Hz), the safety and the single wire safety outputs turn OFF. The PWR/Fault indicator flashes at a 3X rate. When the speed drops below the max speed limit, press the Reset button to clear the fault.

Ratings

The safety function meets the safety performance requirements of SIL CL2 per IEC 62061:2005 and has a Category 3 structure that can be used in systems requiring Performance Levels up to PLd per ISO13829-1:2008. This circuit executes a Safe Limited Speed function.

Safeguarding Applications and Wiring Diagrams

Safe Limited Speed with Guardlocking Interlock and Proximity Sensors

TLS3-GD2, 800F, 872C, GLP, DI, PowerFlex 45

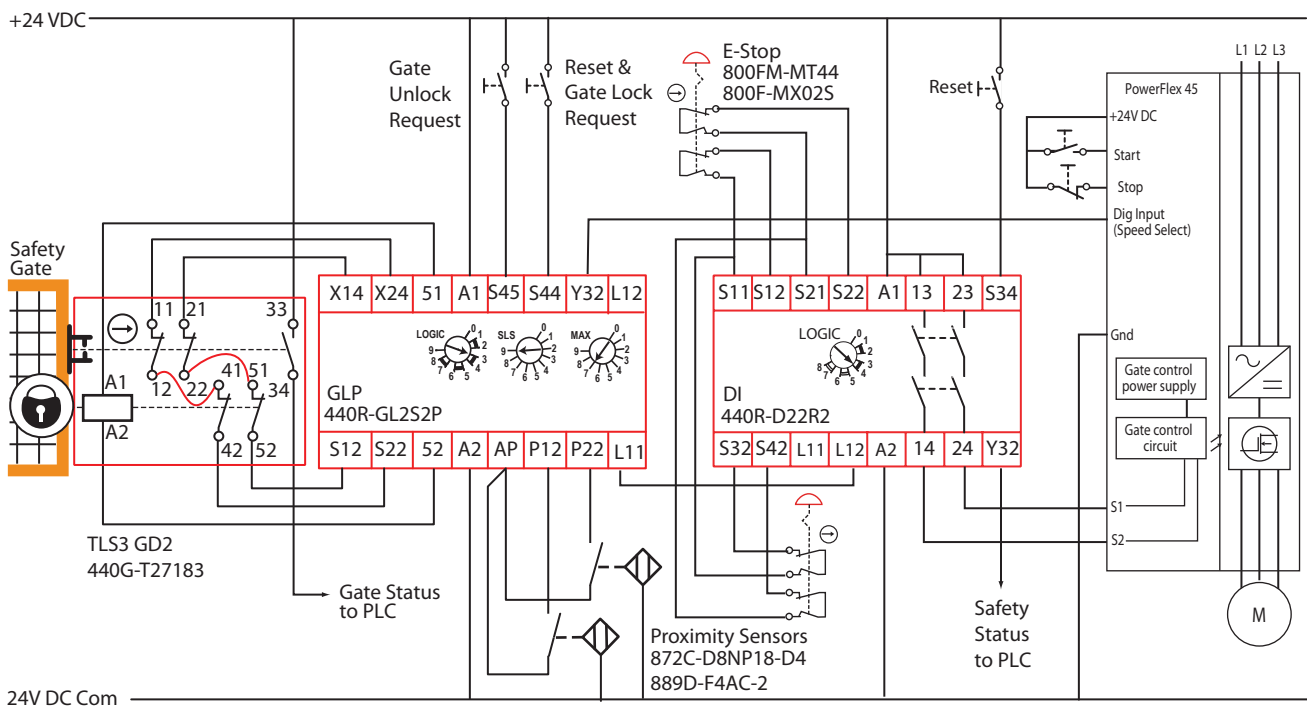

Circuit Status

The gate is closed and locked. The motor is off. The GLP is ready for reset. The GLP has a Logic setting of 3: (Safe Limited Speed with Logic IN OFF), a Safe Limited Speed (SLS) setting of 9 (10 Hz) and a maximum (MAX) speed setting of 7 (1000 Hz). Both E-Stops are closed. The DI is configured to setting 4 [(IN1 AND IN2) AND L12] with monitored manual reset. The single wire safety output (L11) and the GLP auxiliary output (Y32) are OFF. The DI safety outputs are off and the DI auxiliary output (Y32) is ON. NOTE: Start the GLP logic configuration from "9" to configure X14 and X24 for use with safety inputs.

Operating Principle

STARTING: Press the Reset button to turn the GLP safety outputs (L11) ON. This enables the DI relay. Press the Reset button to turn the DI outputs ON and enable the PowerFlex Drive. Press the Start button to turn the motor ON.

STOPPING: Normal production stopping is performed by pressing the Stop button. Access through the safety gate is initiated by pressing the Gate Unlock Request button. The Y32 output of the GLP turns ON and commands the PowerFlex drive to bring the motor to a safe slow speed (less than 10Hz). When the speed detected by the proximity sensors drops below the safe limited speed (10Hz), the gate becomes unlocked. The operator can enter the machine cell, as the motor continues to run at the safe slow speed. After leaving the cell and closing the gate, press the reset button to lock the gate and return the machine to production speeds.

The E-stop buttons can be used to initiate a "coast-to-stop". Press the e-stop and the DI outputs turn off, which commands the drive to a safe off state. The motor coasts to a stop.

Fault Detection

Upon power-up, the safety devices perform internal checks. The GLP sends out test pulses on X14 and X24 to check for faults on the guardlocking switch. The DI sends out test pulses on S11 and S21 to check for faults on the e-stops. The GLP checks to see that the proximity sensors are connected, by requiring that both sensors cannot be OFF at the same time. The L11/L12 connection is Single Wire Safety connection tested for shorts to power or ground when active.

Ratings

The safety functions meet the safety performance requirements of SIL CL2 per IEC 62061:2005 and has a Category 3 structure that can be used in systems requiring Performance Levels up to PLd per ISO13829-1:2008. This circuit executes a Safe Limited Speed function when requesting gate access through the GLP, and a Category 0 stop when pressing the e-stops.